

Bakeout Mantles

- Uniform heating up to 200°C
- Controlled heating temperature and timing
- Minimum space to store
- Meet clean room requirements
- Simple to assemble/remove
- Decrease heat load on laboratory air conditioning
- Lightweight and easy to carry/to handle



Product introduction

The Riber Bakeout set up includes complete coverage of the growth chamber made of flexible mantles for R&D and Production systems. Both Bakeout enclosures are made of fireproof cleanroom-compatible material.

For all Riber systems, heating is performed with heating stations incl. fans and/or heating tapes in order to achieve very high uniform heating of the chamber up to 200°C.

The flexible mantles are fitted together with Velcro fasteners. The main mantle part can be left permanently on the growth chamber.

heating tapes which completely cover the equipment, heated up to 150°C and covered with Velcro mantles as well when applicable.

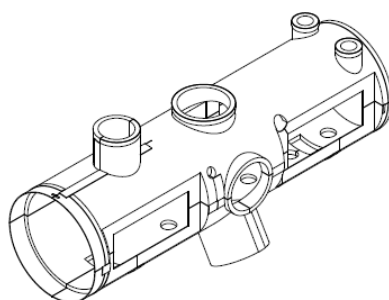

Example of MBE 6000 shuttle bakeout mantle

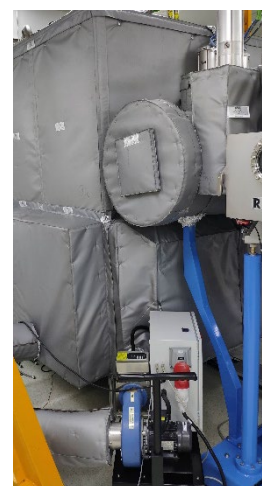

Bakeout heating station

Bakeout for transfer system is made of

Specifications

Characteristics	Bayard Alpert gauge
Bakeout type	Heating station with fans or heating tapes + flexible mantles - Velcro fasteners
Max achievable internal temperature	200°C Growth chamber / 150°C other chambers & transfer
Temperature tolerance	+/-20°C
Max external bakeout temperature	50°C

Ordering information – Bakeout mantles

As bakeout mantles may be tailored to fit system configuration, please contact Riber for detailed ordering information

RIBER SALES AND SERVICE NETWORK

For more information, please contact your local sales representative

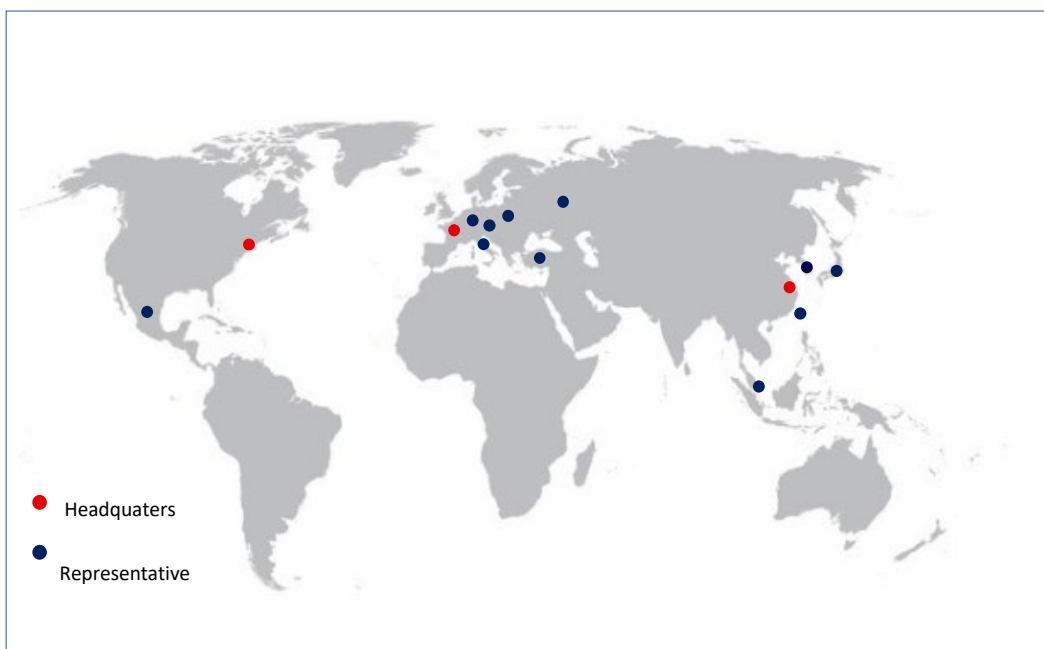

FRANCE

RIBER
 31, Rue Casimir Périer
 95 873 Bezons Cedex
 France
 Tel : +33(0)1 3996 65 91
 Fax : +33(0)1 3947 4562
 Email : customerservice@riber.fr

USA/CANADA

RIBER Inc
 216, Route 206, Suite 17
 Hillsborough
 NJ 08844 USA
 Tel : +1 732 603 0680
 Fax : +1 732 603 8611
 Email : customerservice@riber-us.com

CHINA

RIBER China
 Room 1-8, Building A, Dart Tech Park
 #516 Wenchuan Road, Baoshan District
 Shanghai PR China
 Tel : +86 (21) 635 66 266
 Fax : +86 (21) 635 66 266
 Email : customerservice@riber.cn

OTHER COUNTRIES

RIBER
 31, Rue Casimir Périer
 95 873 Bezons Cedex
 France
 Tel : +33(0)1 3996 65 91
 Fax : +33(0)1 3947 4562
 Email : customerservice@riber.fr

Email: info@riber.com

Website: www.riber.com